

Acquisition Process Model

1.4 Develop and Operate Systems (Acquire)

Go Up 1 Level

Governing

DCO URL: <https://connect.dco.dod.mil/r43017508>
Copy and Paste the above URL into Internet Explorer

Core

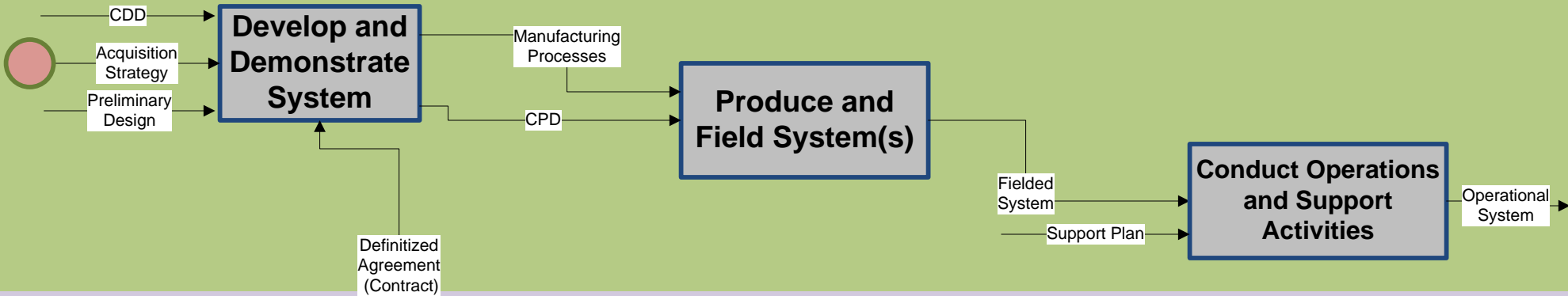

Enabling



Acquisition Process Model

1.4.1 Develop and Demonstrate System

Go Up 1 Level

Governing

Core

Enabling

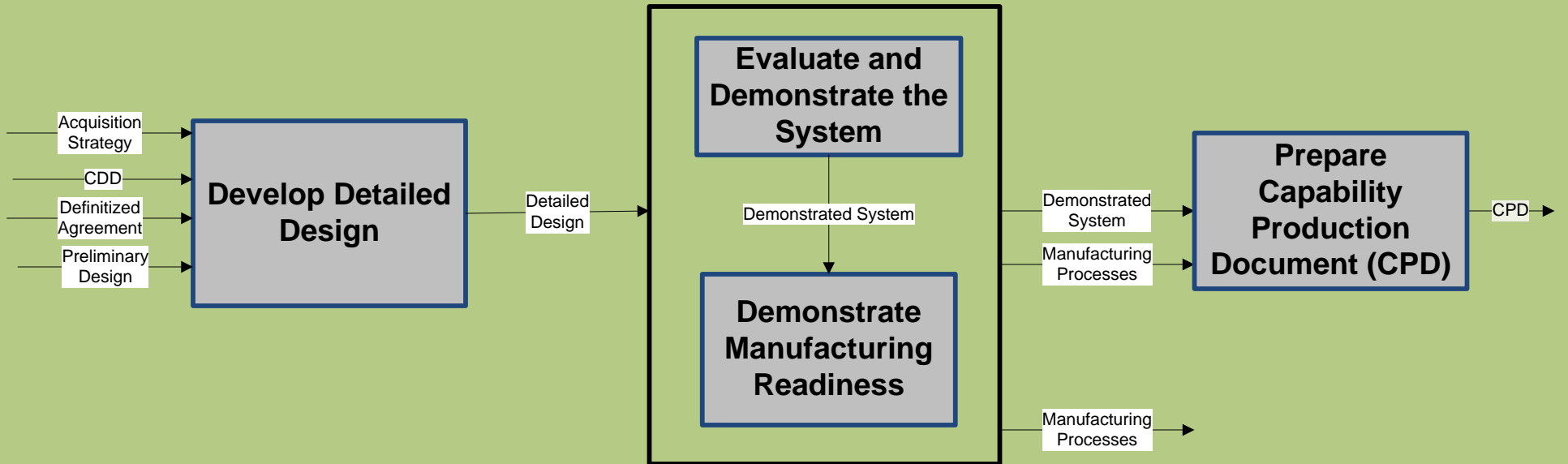

Acquisition Process Model

1.4.1.1 Develop Detailed Design

Go Up 1 Level

Integrated System Design

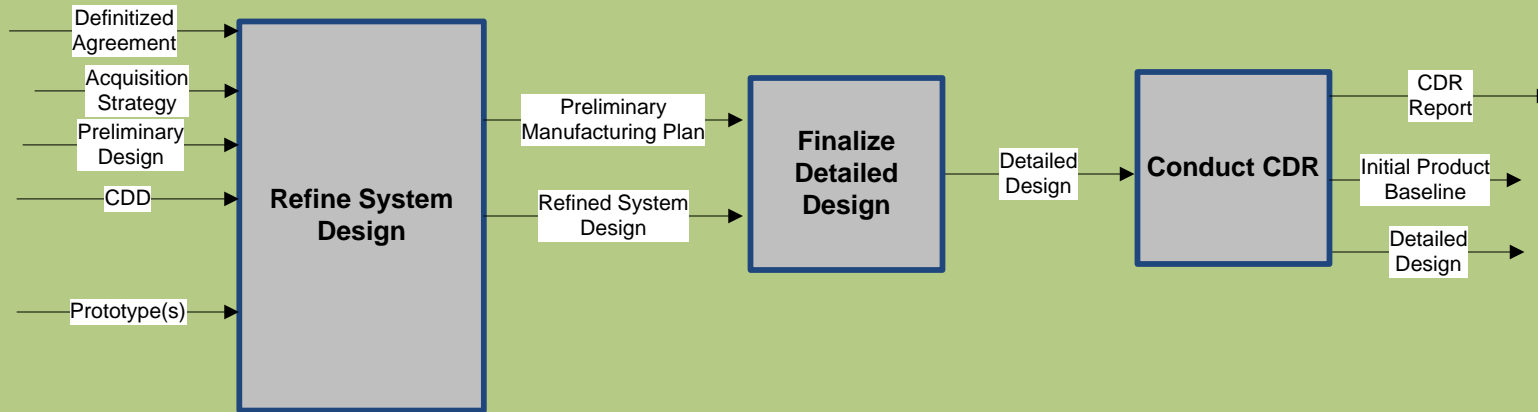

*Note: Competitive Prototyping is required for all MDAPS, but this requirement can be waived for some ACAT III Programs
See DoD 5000.02 Section 5*

Reference DAG
Section 4.3.3.3

Acquisition Process Model

1.4.1.1 Refine System Design

Go Up 1 Level

Governing

Iterative Process that occurs throughout the EMD Phase

Core

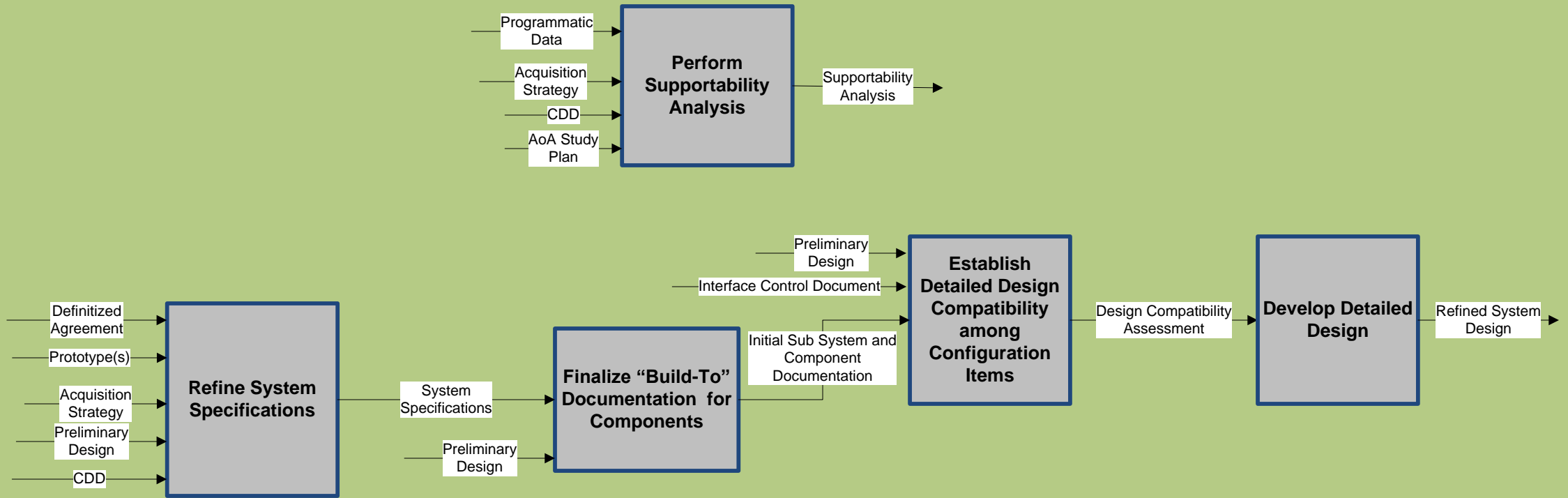

Enabling



Acquisition Process Model

1.4.1.1.3 Finalize Detailed Design

Go Up 1 Level

Governing

Core

Enabling

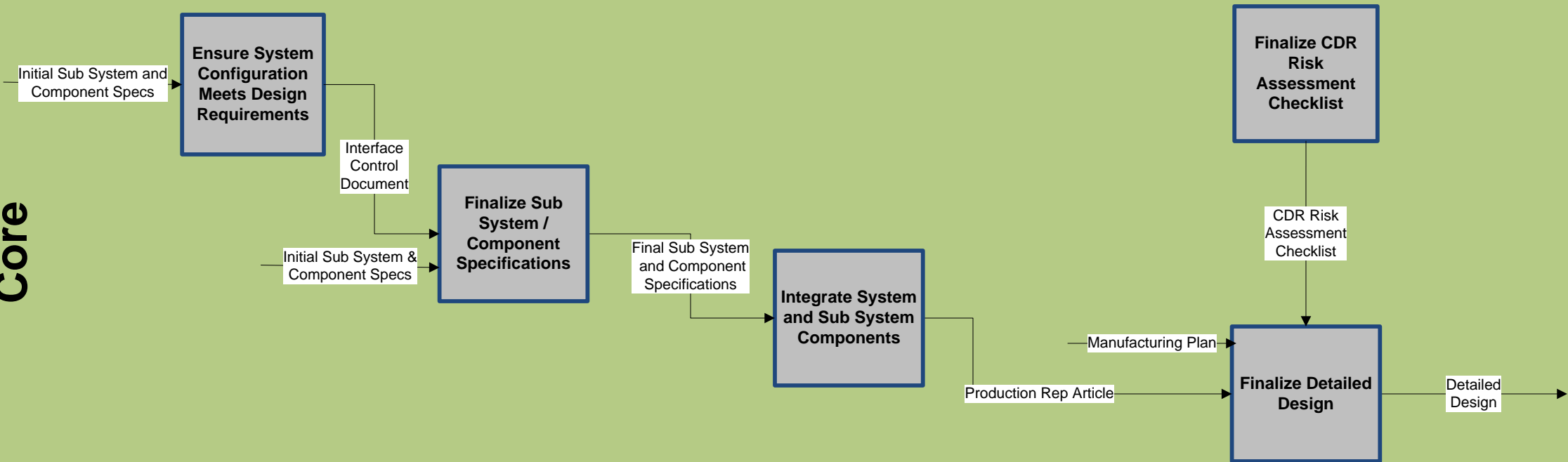

Acquisition Process Model

1.4.1.1.3.3 Develop CDR Risk Assessment Checklist

Go Up 1 Level

Governing

Core

Enabling

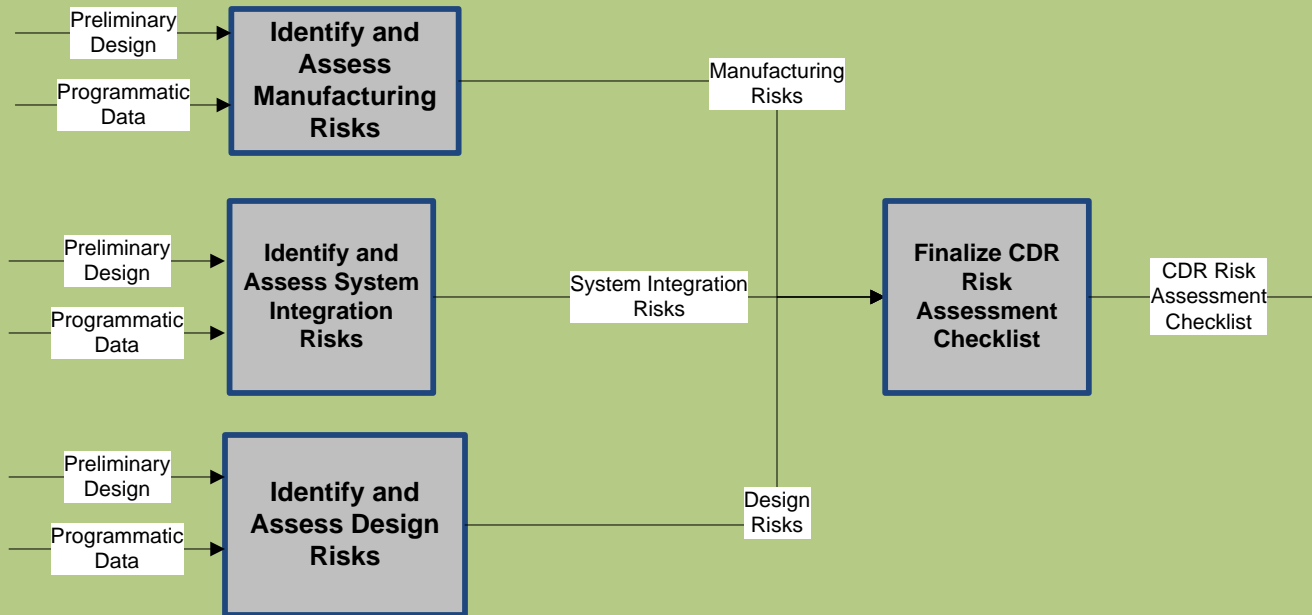

Acquisition Process Model

1.4.1.1.4 Critical Design Review (CDR)

Go Up 1 Level

Governing

Core

Enabling

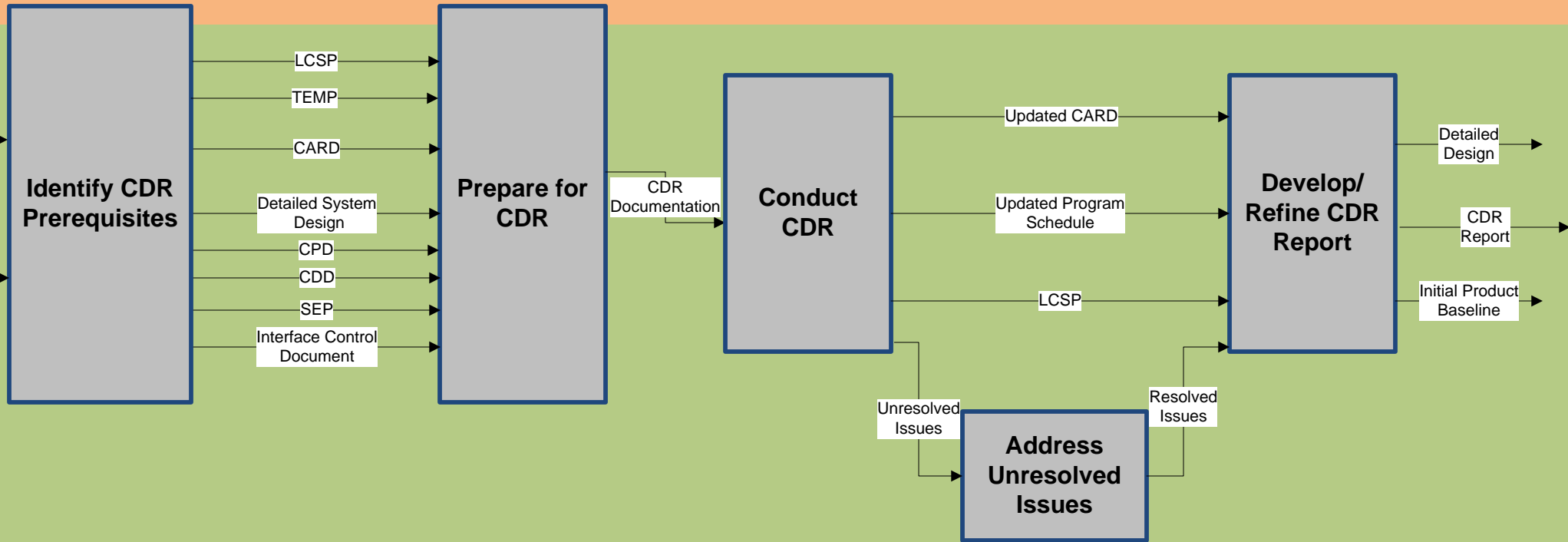

Reference DAG
Section 4.3.3.4.2

Acquisition Process Model

1.4.1.2 Evaluate and Demonstrate the System

Go Up 1 Level

Governing

Core

Enabling

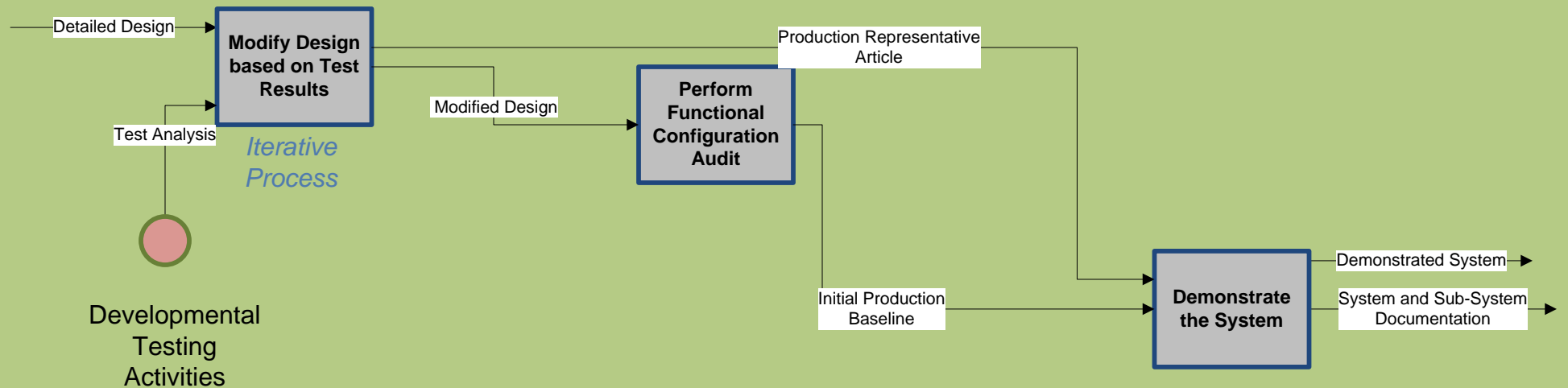

Acquisition Process Model

1.4.1.2.1 Modify Design Based on Test Results

Go Up 1 Level

Governing

Core

Enabling

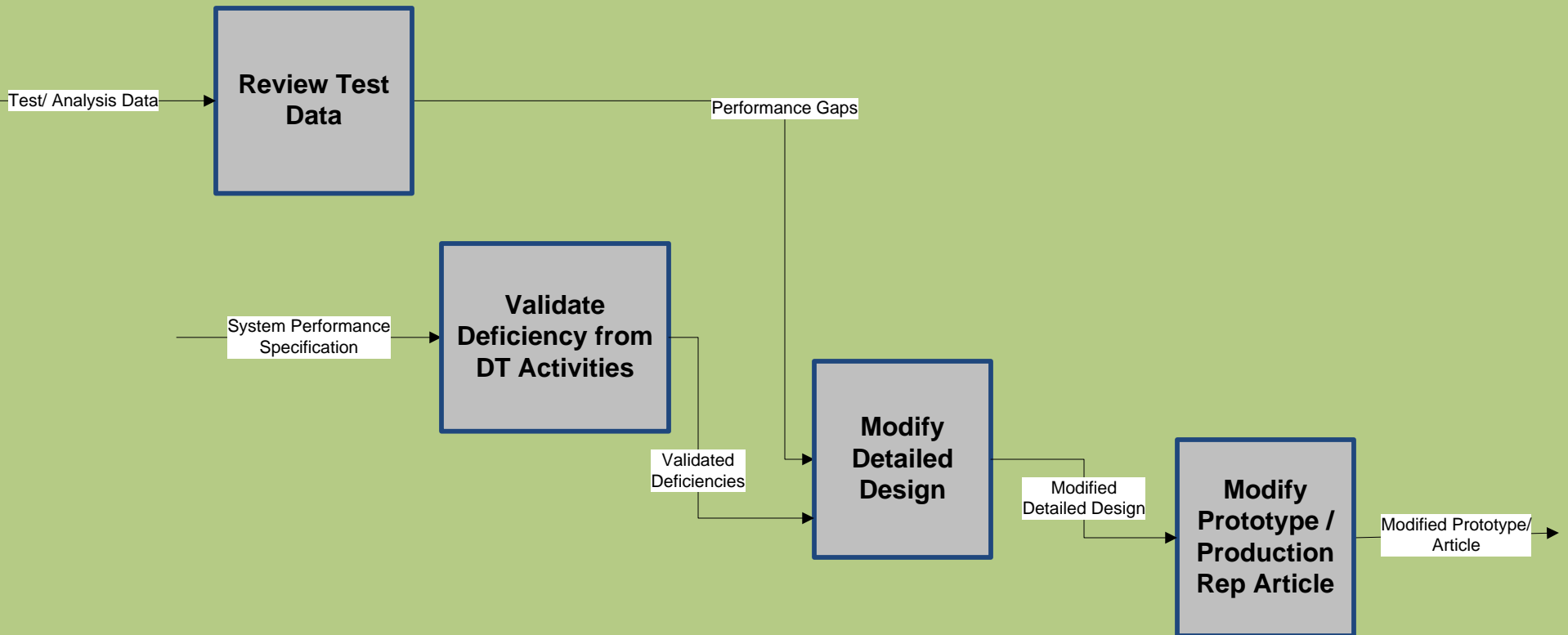

Acquisition Process Model

1.4.1.2.2 Address Functional Configuration Audit (FCA)

Go Up 1 Level

Governing

Core

Enabling

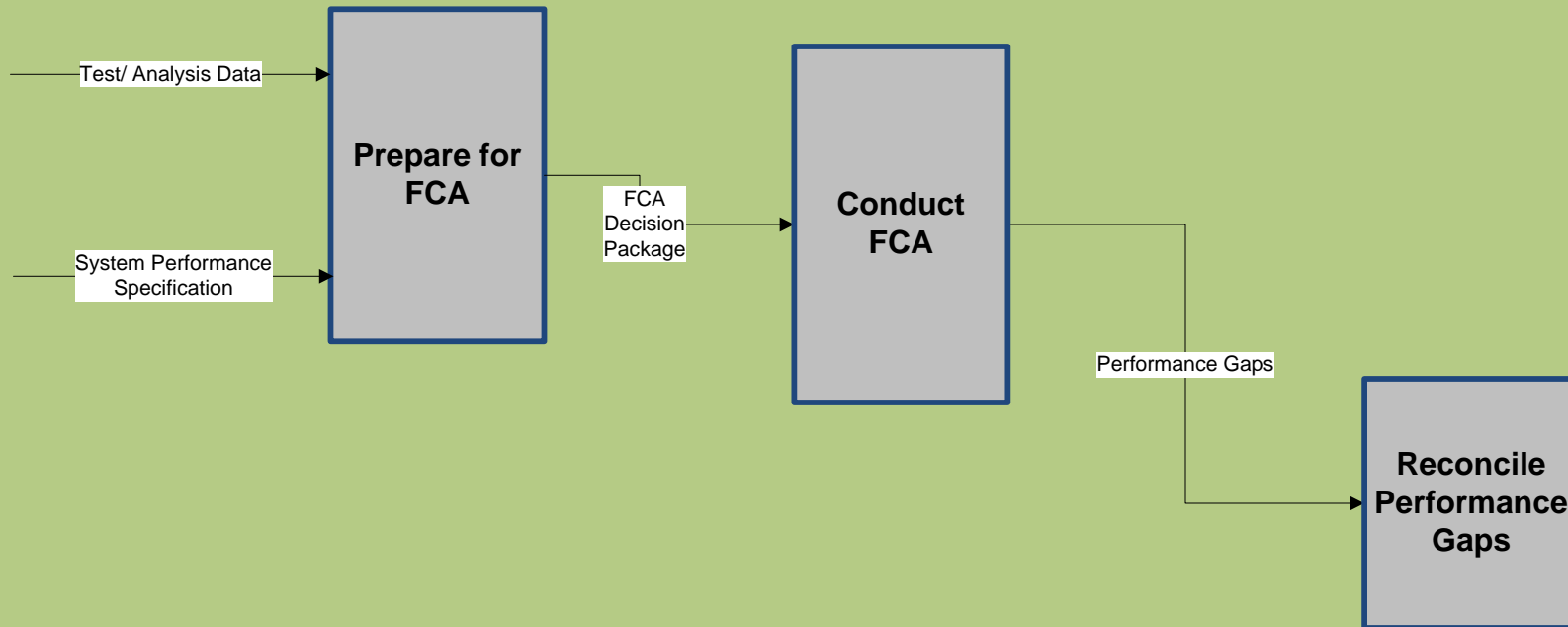

Acquisition Process Model

1.4.1.2.3 Demonstrate the System

Go Up 1 Level

Governing

Core

Enabling

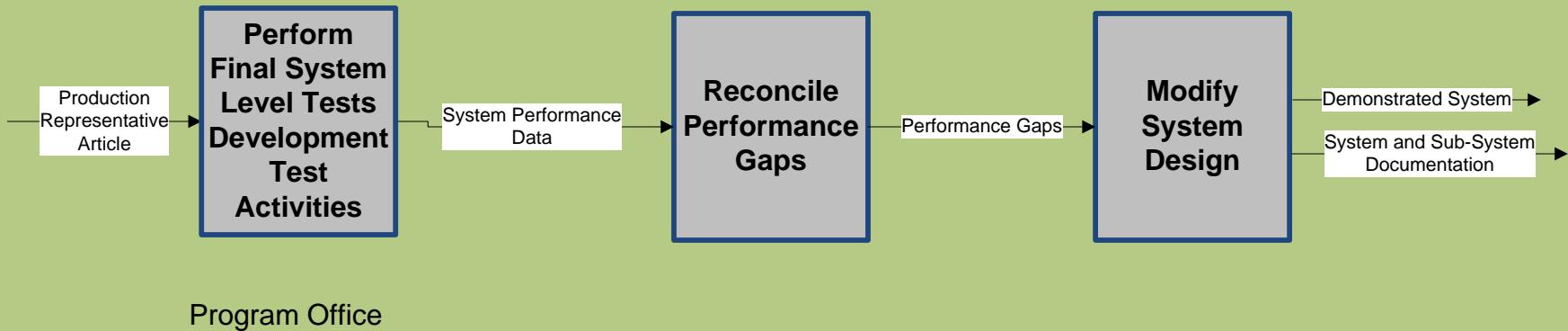

Acquisition Process Model

1.4.1.3 Demonstrate Manufacturing Readiness

Go Up 1 Level

Governing

Core

Enabling

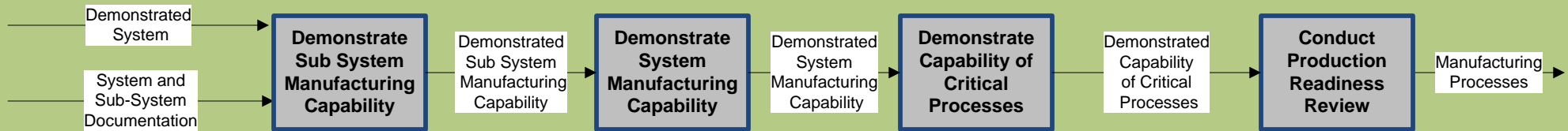

Acquisition Process Model

1.4.1.4 Develop CPD

These Buttons are disabled in this version

Go Up 1 Level

Return to AFROC Summary

Return to MS B to MS C

Governing

Core

Enabling

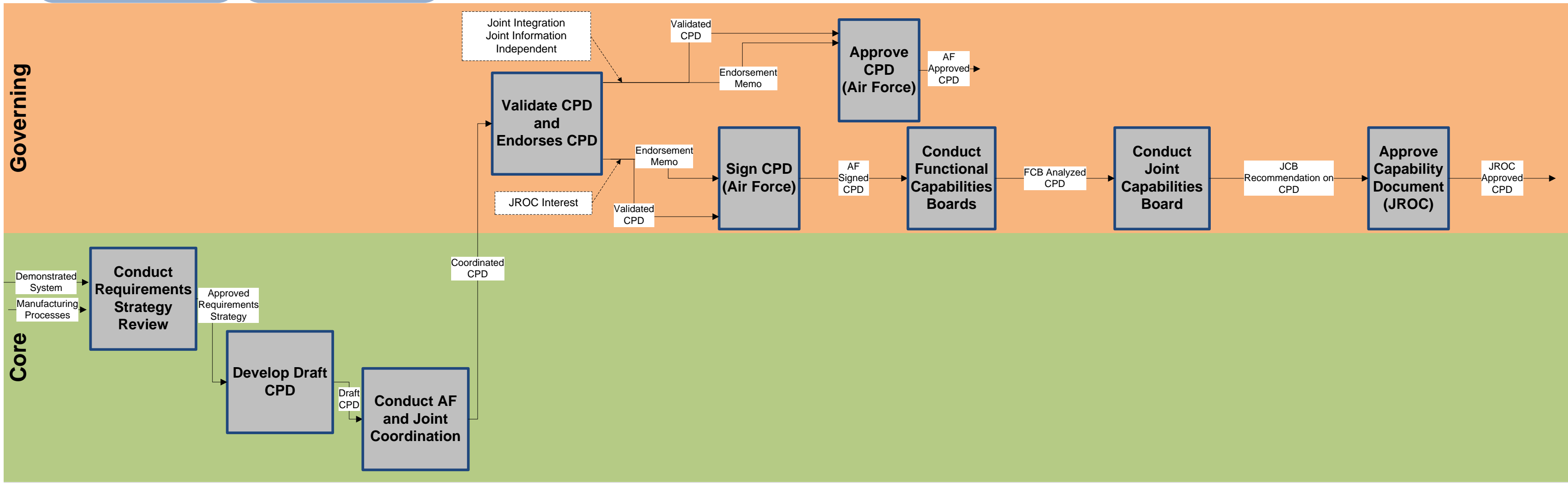

[Click Here to View CJCSI 3170.01](#)

Acquisition Process Model

1.4.2 Produce and Field System(s)

Go Up 1 Level

Governing

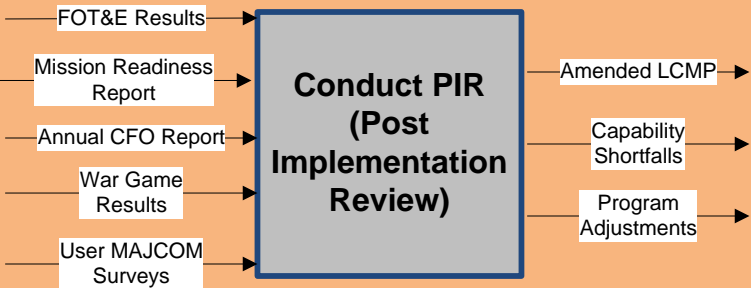

Core

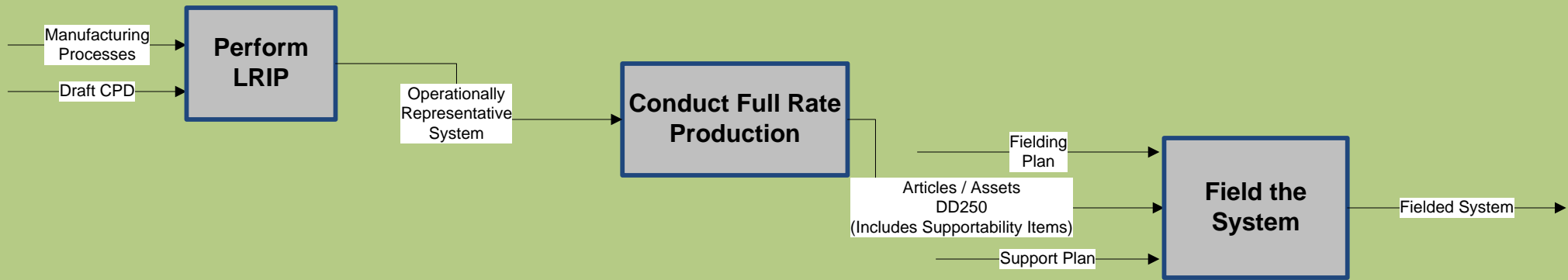

Enabling

Acquisition Process Model

1.4.2.1 Produce Operational Representative System

Go Up 1 Level

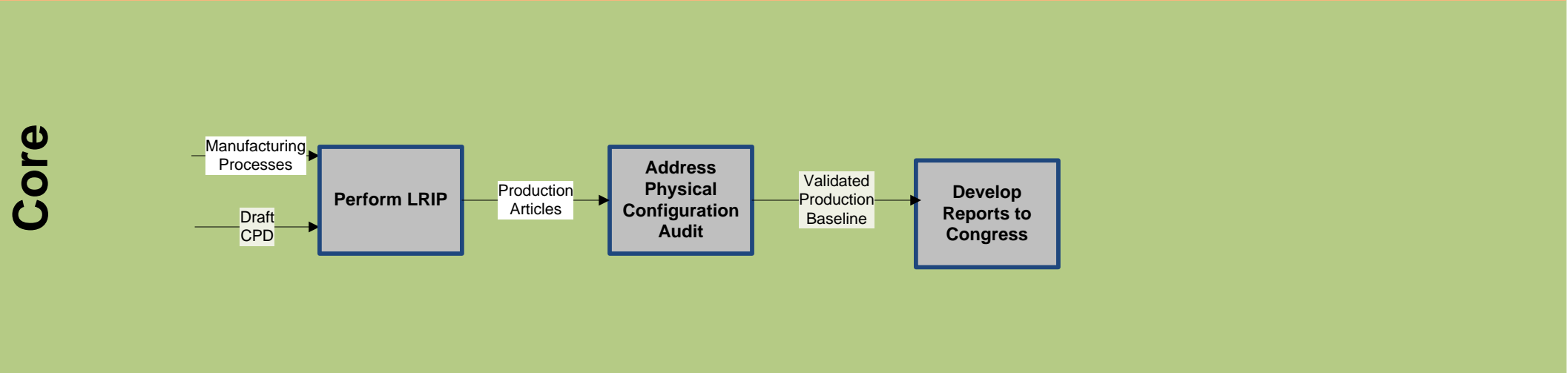

Acquisition Process Model

1.4.2.1.1 Perform Low Rate Initial Production

Go Up 1 Level

Governing



Core

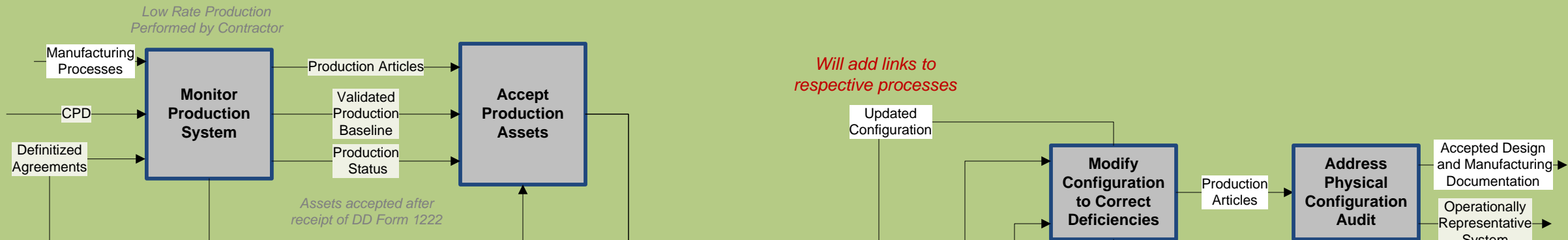

Enabling

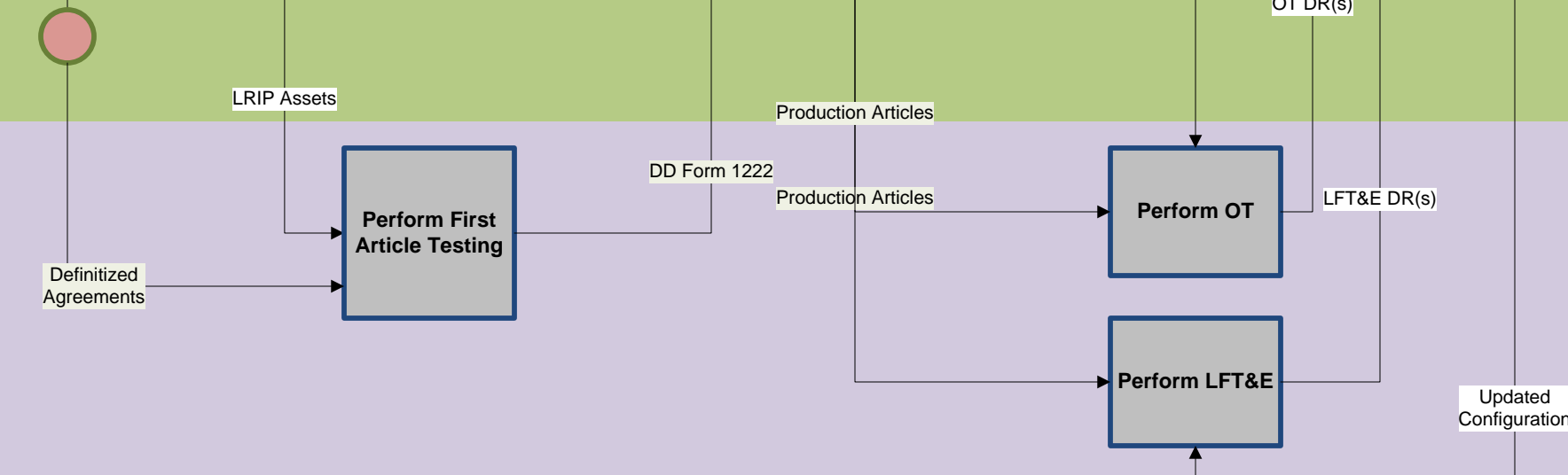

Acquisition Process Model

1.4.2.1.2 Perform First Article Testing (FAT)

Go Up 1 Level

Governing

Core

Enabling

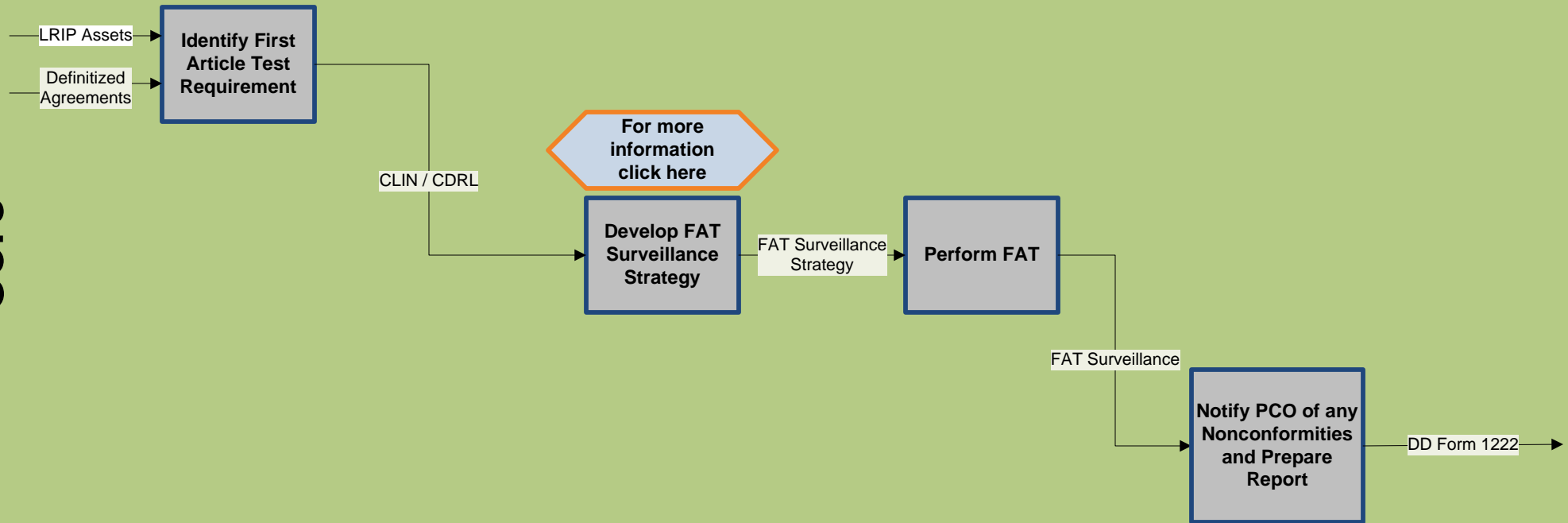

Acquisition Process Model

1.4.2.1.3 Develop Reports to Congress

Go Up 1 Level

Core

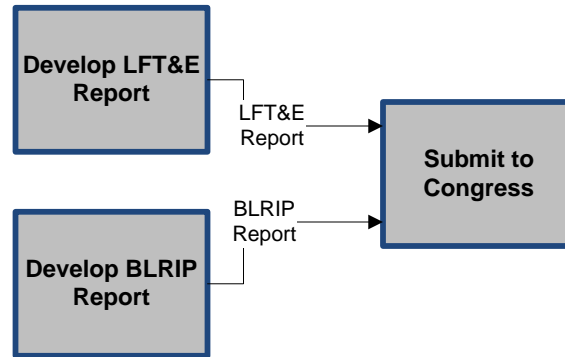

Enabling

Acquisition Process Model

1.4.2.1.7 Address Physical Configuration Audit (PCA)

Go Up 1 Level

Governing

Core

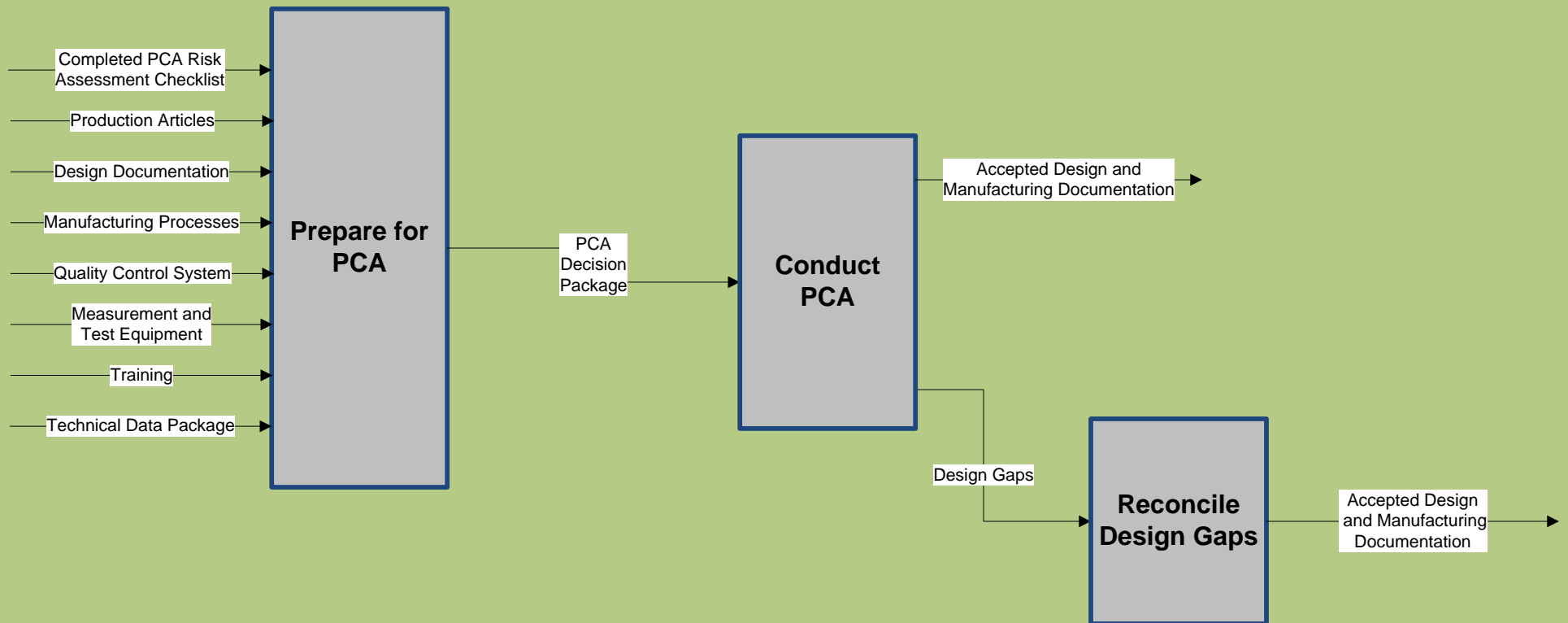

Acquisition Process Model

1.4.2.2 Conduct Full Rate Production

Go Up 1 Level

Governing

Core

Enabling

*Add hyperlink to FRP
Review in Process 1.1.3.8*

Full Rate Production

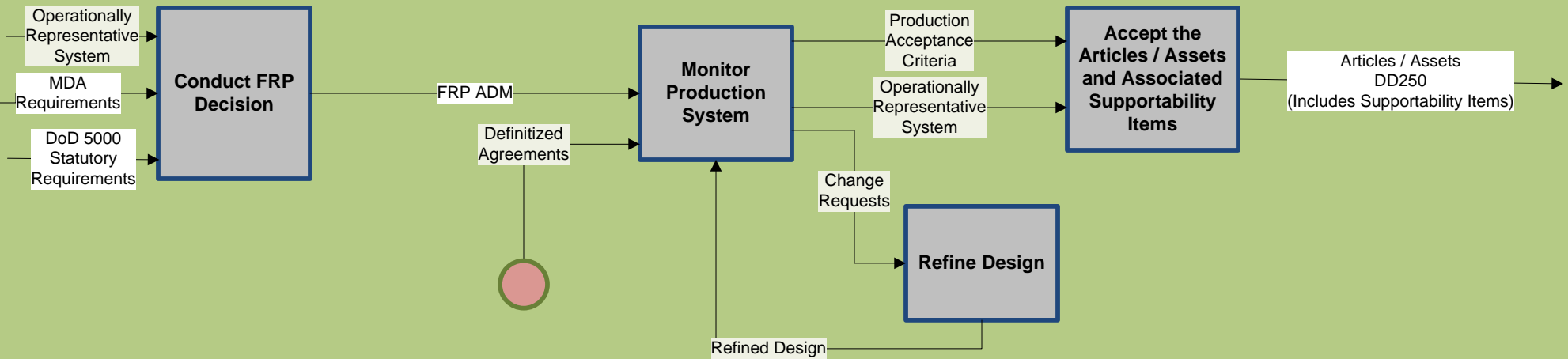

Acquisition Process Model

1.4.2.3 Field the System

Go Up 1 Level

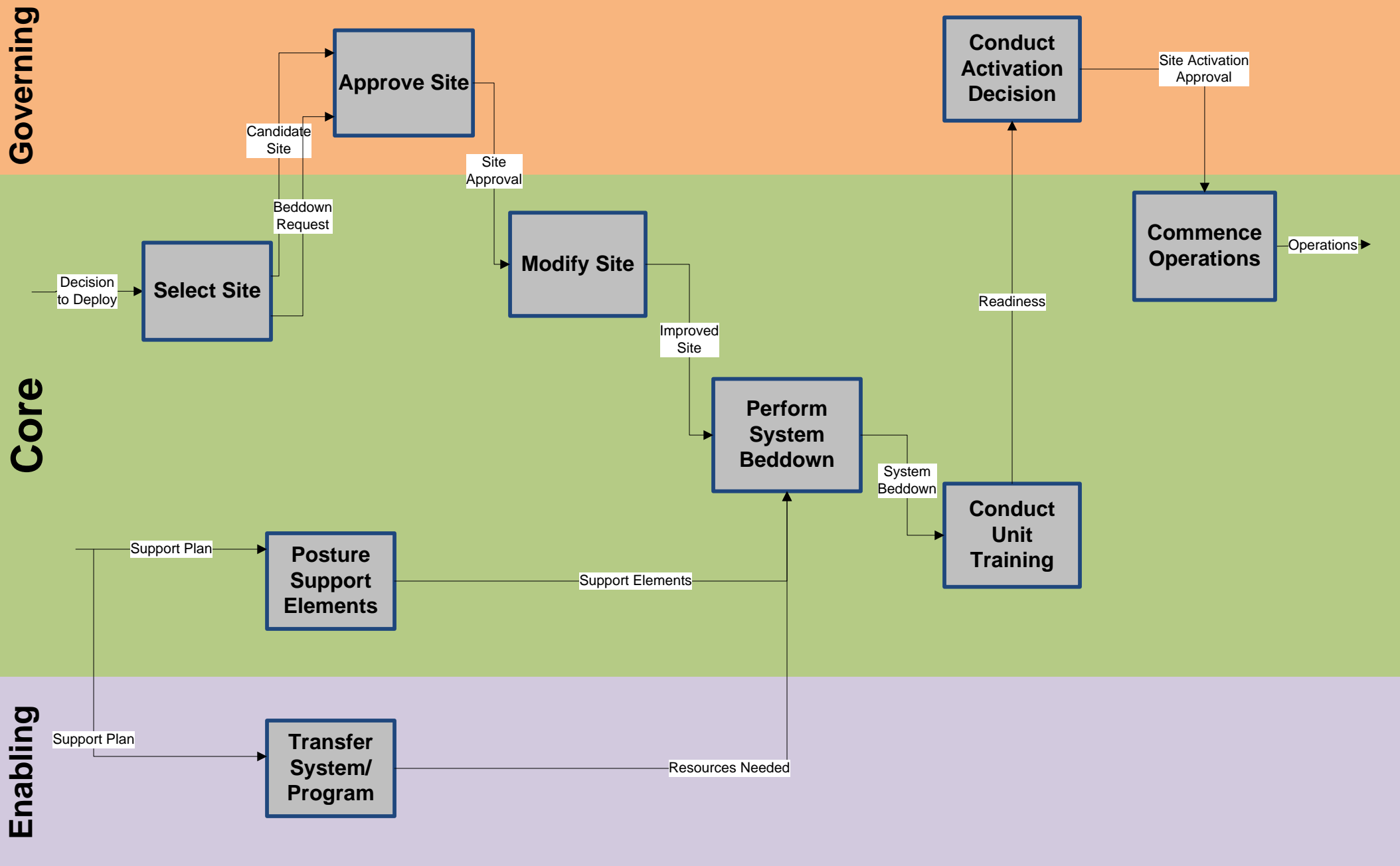

Acquisition Process Model

1.4.2.3.1 Select Site

Go Up 1 Level

Governing



Core

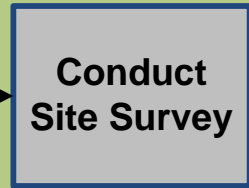
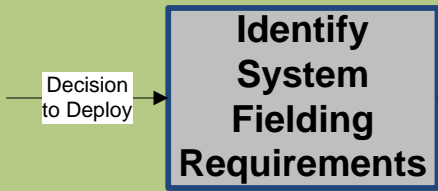

Decision to Deploy

Site Requirements

Approval to Survey Site

Site Requirements Report

Candidate Site

Beddown Request

Enabling

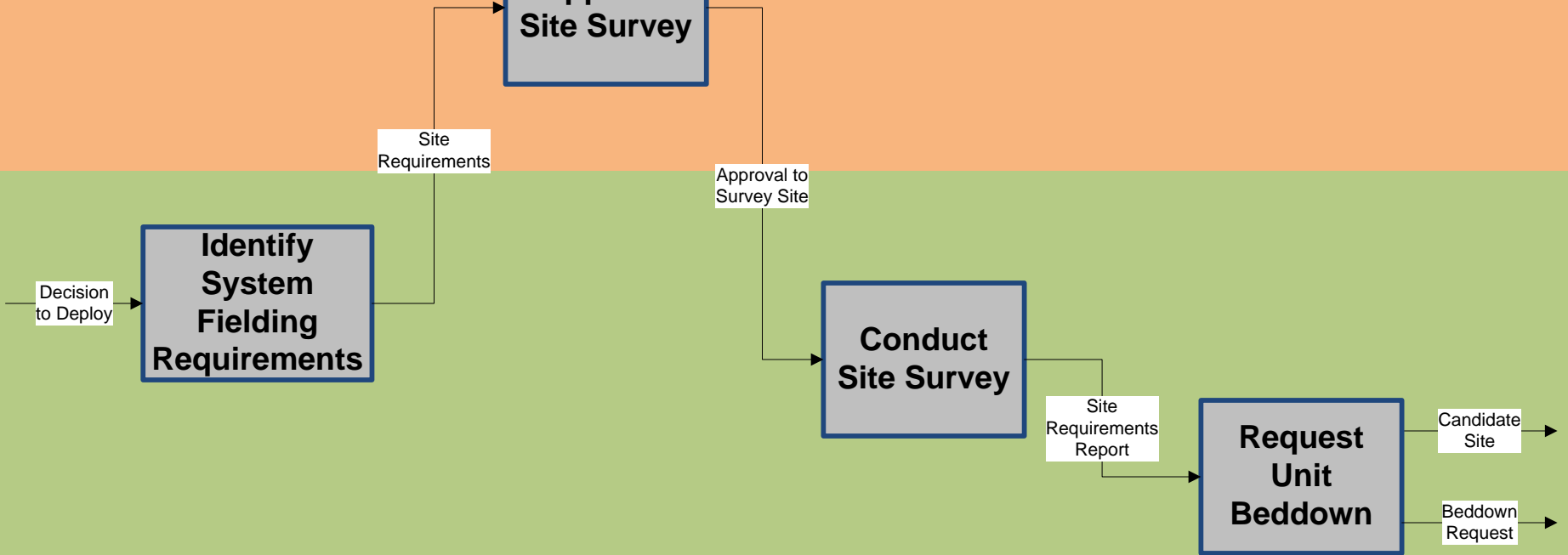

Acquisition Process Model

1.4.2.3.1.3 Conduct Site Survey

Go Up 1 Level

Governing

Core

Enabling

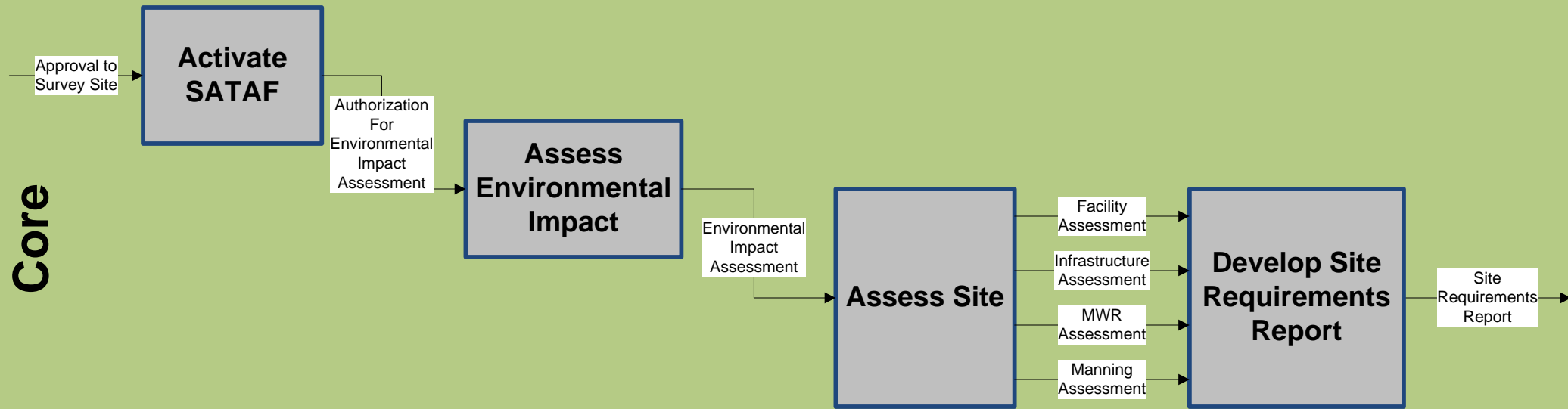

Acquisition Process Model

1.4.2.3.1.3.3 Assess Site

Go Up 1 Level

Governing

Core

Enabling

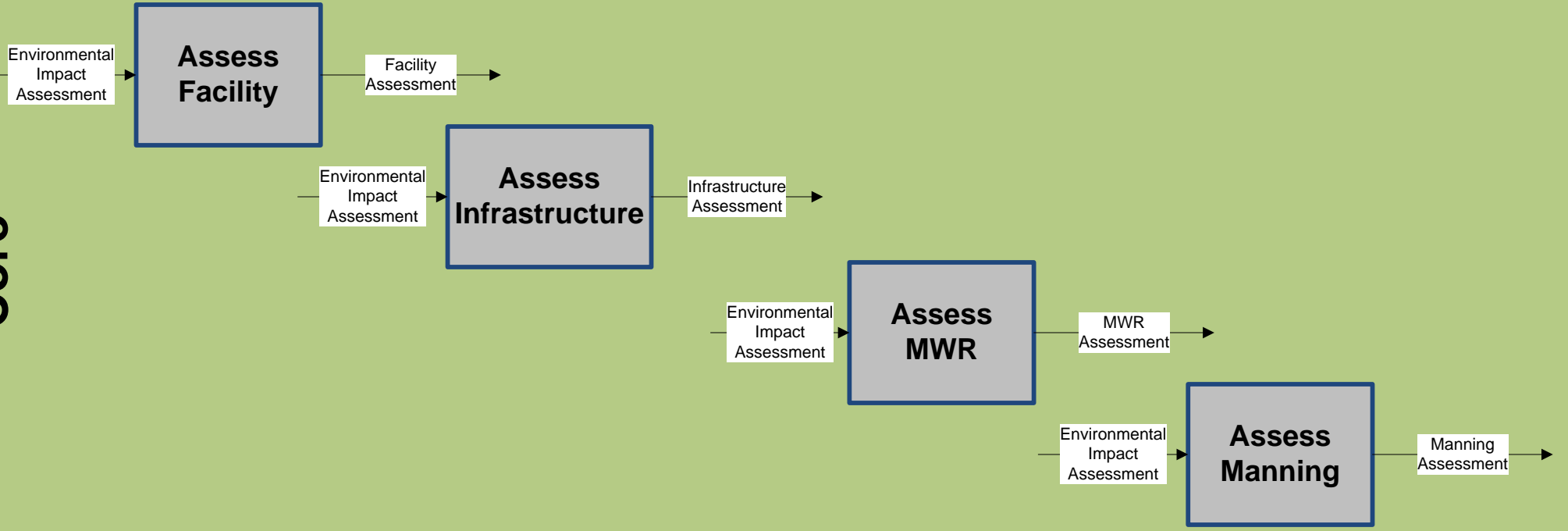

Acquisition Process Model

1.4.2.3.3 Conduct Site Survey

Go Up 1 Level

Governing

Certify Facility

Certified Facility

Core

Identify Facility & Construction Needs

Facility & Construction Needs

Design Facility & Infrastructure

Identify Manpower Needs

Manpower Needs

Perform Construction

Uncertified Facility

Proposed Facility & Infrastructure Design

Construction Funding

Enabling

Request MILCON

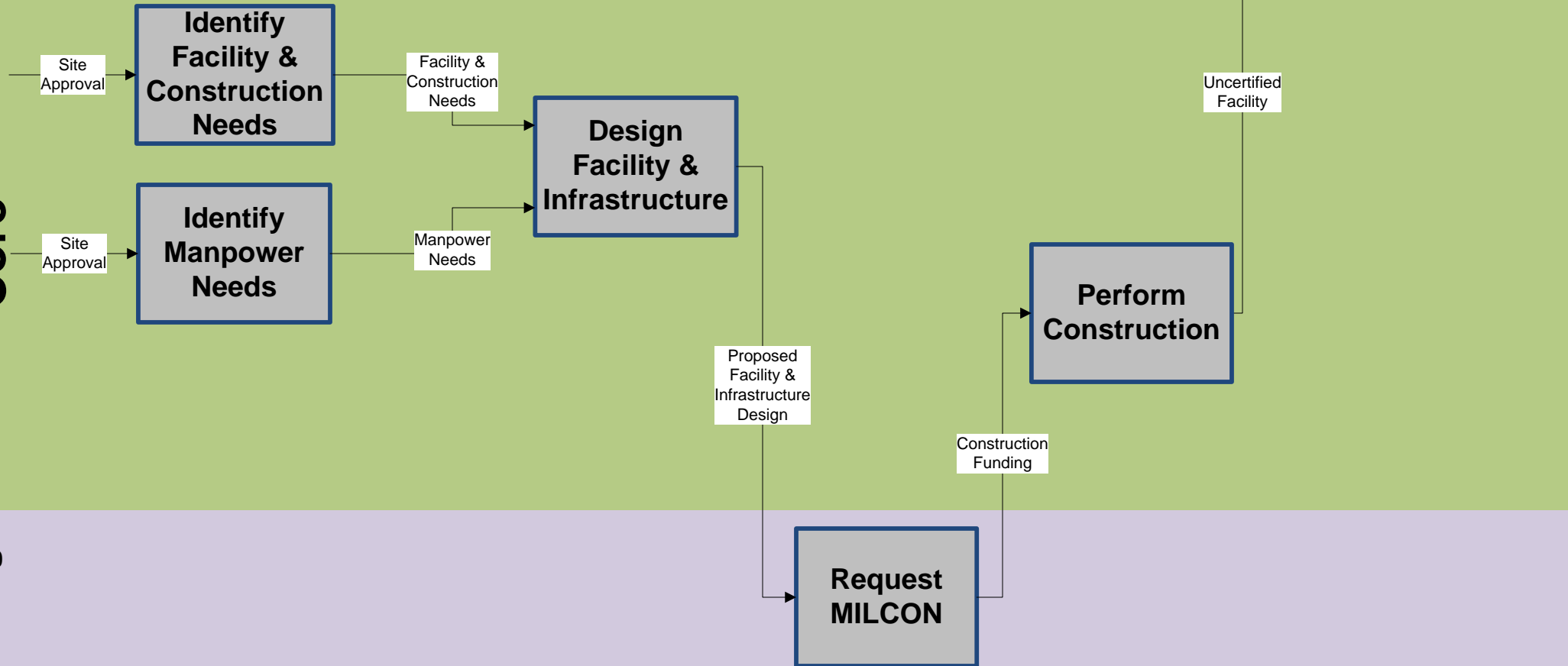

Acquisition Process Model

1.4.2.3.3.2 Identify Manpower Needs

Go Up 1 Level

Governing

Core

Enabling

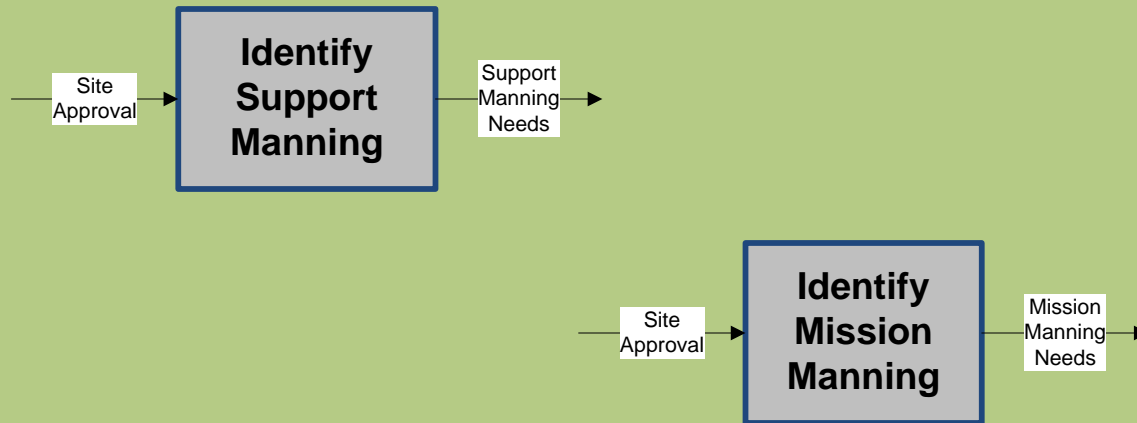

Acquisition Process Model

1.4.2.3.4 Transfer System/Program

Go Up 1 Level

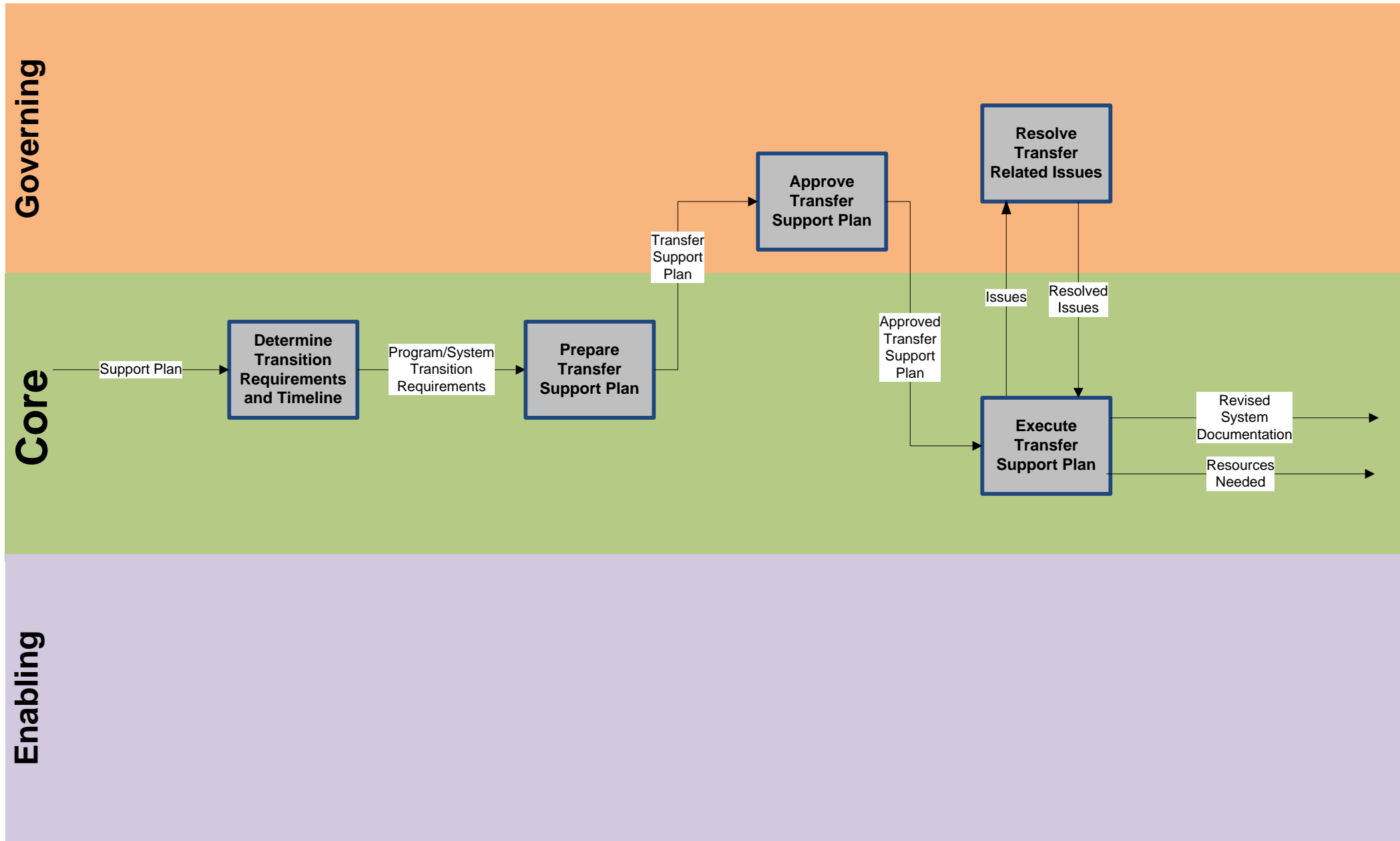

FAT Surveillance Strategy

[Return](#)

4.1. Contractor Testing – The strategy shall:

- Verify the supplier's inspection of critical or major product characteristics or processes identified in the FAT report by independently inspecting or witnessing the supplier's inspection or testing of these characteristics. This includes characteristics or processes performed at subcontractors.
- If sampling is authorized, perform sample verification of all other (non-critical or non-major) product characteristics or processes to the degree necessary to establish confidence of product conformance to technical specifications
- **If required by contract, ensure the manufacturing processes, materials, and facilities used to produce the FAT product are the same as those to be used to produce production runs ([FAR 52.209-3](#); Alternate 1, para i).**
- **Ensure the test report clearly demonstrates the products conformance to technical specifications. Perform any other activities requested by QALI.**

4.2. Government Testing – The strategy shall:

- **Ensure the supplier's inspection and test records clearly demonstrate the products conformance to technical specifications. The records will be sent to the approval authority when required by contract.**
- **If required by contract, ensure the manufacturing processes, materials, and facilities used to produce the FAT product are the same as those to be used to produce production runs ([FAR 52.209-4](#); Alternate 1, para j).**
- **Perform any other activities requested by QALI.**

For more information, please visit this site